

# E0C6262

## 4-bit Single Chip Microcomputer



- Core CPU
- 3 ↔ 5V Level Shifter
- SVD Circuit
- Serial Interface

### DESCRIPTION

The E0C6262 is a CMOS 4-bit microcomputer with 4-bit core CPU (E0C6200A), ROM, RAM, time base counter, serial interface, supply voltage detection (SVD) circuit and a programmable timer/event counter.

The E0C6262 features low power dissipation and is ideal for battery-powered equipment.

### FEATURES

- CMOS LSI 4-bit parallel processing
- Clock ..... 32.768kHz (Typ.) and 1MHz (Typ.) (software selectable)
- Instruction set ..... 100 instructions
- Instruction execution time ..... 153μsec, 214μsec or 366μsec at 32kHz  
(depending on instruction)  
5μsec, 7μsec or 12μsec at 1MHz  
(depending on instruction)
- ROM capacity ..... 2,048 × 12 bits
- RAM capacity ..... 128 × 4 bits
- Input port ..... 8 bits (pull-up resistors are available by mask option)
- Output port ..... 8 bits (clock/alarm output is available by mask option)
- I/O port ..... 16 bits (serial I/O is available by mask option)
- Synchronized serial I/O port ..... 1 port (optional)
- Clock timer
- Watchdog timer
- Programmable timer
- Event counter ..... 8 bits
- 5V level-shifter interface
- Supply voltage detection (SVD) circuit .. Two-level detection  
1.1V to 1.2V ± 50mV, 2.2V to 2.4V ± 100mV
- Interrupts ..... External : Input interrupt      2 lines  
Internal : Timer interrupt      2 lines  
Serial I/O interrupt      1 line
- Oscillator startup voltage ..... 0.9V minimum (OSC1)
- Current consumption ..... E0C62L62      HALT mode (32kHz)      : 2.0μA  
                                                                                                                         OPERATING mode (32kHz) : 5.0μA  
                                                                                                                         E0C6262      HALT mode (32kHz)      : 3.0μA  
                                                                                                                         OPERATING mode (32kHz) : 7.0μA  
                                                                                                                         E0C62A62      OPERATING mode (1MHz) : 300μA
- Package ..... QFP6-44pin (plastic), QFP12-48pin (plastic)  
Die form

### LINE UP

Model	Supply voltage	Clock
<b>E0C62L62</b>	1.5V (0.8V to 2.2V)	32kHz (Crystal oscillation)
<b>E0C6262</b>	3.0V (2.2V to 5.0V)	32kHz (Crystal oscillation)
<b>E0C62A62</b>	3.0V (2.2V to 5.0V)	32kHz (Crystal oscillation) & 1MHz (Ceramic or CR oscillation)

# E0C6262

## ■ BLOCK DIAGRAM

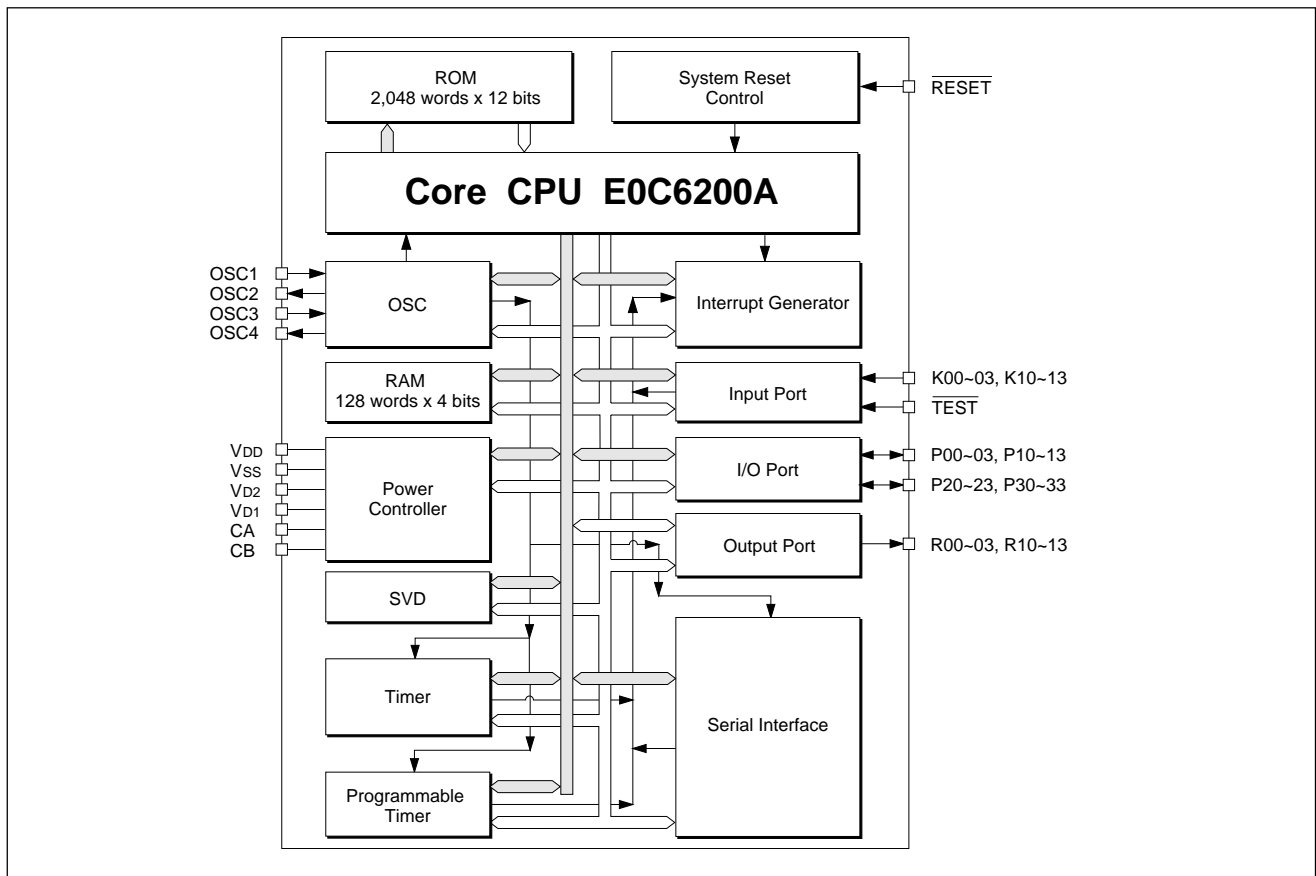

## ■ PIN CONFIGURATION

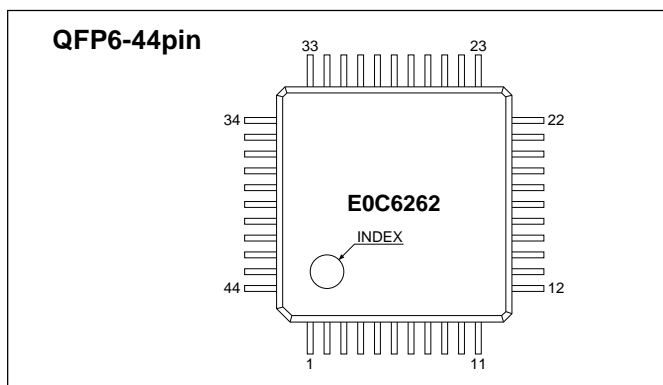

No.	Pin name	No.	Pin name	No.	Pin name	No.	Pin name
1	P10	12	R13	23	Vd2	34	K01
2	P11	13	P20	24	OSC4	35	K02
3	P12	14	P21	25	OSC3	36	K03
4	P13	15	P22	26	Vd1	37	R00
5	K10	16	P23	27	OSC2	38	R01
6	K11	17	P30	28	OSC1	39	R02
7	K12	18	P31	29	VdD	40	R03
8	K13	19	P32	30	Vss	41	P00
9	R10	20	P33	31	TEST	42	P01
10	R11	21	CA	32	RESET	43	P02
11	R12	22	CB	33	K00	44	P03

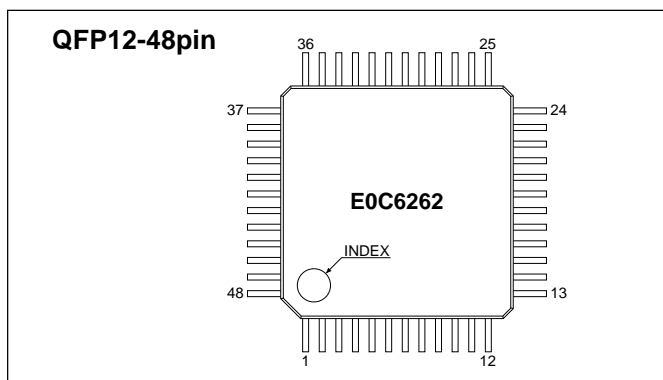

No.	Pin name	No.	Pin name	No.	Pin name	No.	Pin name
1	K01	13	P10	25	R13	37	Vd2
2	K02	14	P11	26	P20	38	OSC4
3	K03	15	P12	27	P21	39	OSC3
4	R00	16	P13	28	P22	40	Vd1
5	R01	17	K10	29	P23	41	OSC2
6	R02	18	K11	30	P30	42	OSC1
7	N.C.	19	N.C.	31	N.C.	43	VdD
8	R03	20	K12	32	P31	44	Vss
9	P00	21	K13	33	P32	45	N.C.
10	P01	22	R10	34	P33	46	TEST
11	P02	23	R11	35	CA	47	RESET
12	P03	24	R12	36	CB	48	K00

N.C. = No Connection

## PIN DESCRIPTION

Pin name	Pin No.		In/Out	Function
	QFP6-44pin	QFP12-48pin		
VDD	29	43	I	Power source (+) terminal
VSS	30	44	I	Power source (-) terminal
VD1	26	40	-	Oscillation and internal logic system regulated voltage
VD2	23	37	-	Oscillation and internal logic system boosted voltage (At 6262/62A62 this is connected to VDD)
CA, CB	21, 22	35, 36	-	Booster capacitor connecting terminal (At 6262/62A62 this is connected to VDD)
OSC1	28	42	I	Crystal oscillation input terminal
OSC2	27	41	O	Crystal oscillation output terminal
OSC3	25	39	I	Ceramic or CR oscillation input terminal (selected by mask option, 62A62 only)
OSC4	24	38	O	Ceramic or CR oscillation output terminal (selected by mask option, 62A62 only)
K00-K03	33-36	48, 1-3	I	Input terminal
K10-K13	5-8	17, 18, 20, 21	I	
P00-P03	41-44	9-12	I/O	
P10-P13	1-4	13-16	I/O	
P20-P23	13-16	26-29	I/O	
P30-P33	17-20	30, 32-34	I/O	I/O terminal (Serial I/O function is selected by mask option)
R00-R03	37-40	4-6, 8	O	Output terminal
R10-R13	9-12	22-25	O	Output terminal (DC, buzzer, clock and SRDY output may be selected by mask option)
RESET	32	47	I	Initial reset input terminal
TEST	31	46	I	Test input terminal

## ELECTRICAL CHARACTERISTICS

### Absolute Maximum Ratings

#### E0C6262/62A62

(VSS=0V)

Rating	Symbol	Value	Unit
Supply voltage	VDD	-0.5 to 5.5	V
Input voltage (1)	VI	-0.5 to VDD + 0.3	V
Input voltage (2)	VIOSC	-0.5 to VD1 + 0.3	V
Permissible total output current *1	$\Sigma I_{VDD}$	5	mA
Operating temperature	Topr	-20 to 70	°C
Storage temperature	Tstg	-65 to 150	°C
Soldering temperature / Time	Tsol	260°C, 10sec (lead section)	-
Permissible dissipation *2	PD	250	mW

\*1: The permissible total output current is the sum total of the current (average current) that simultaneously flows from the output pins (or is draw in).

\*2: In case of plastic package (QFP6-44pin, QFP12-48pin).

#### E0C62L62

(VSS=0V)

Rating	Symbol	Value	Unit
Supply voltage	VDD	-0.5 to 2.5	V
Input voltage (1)	VI	-0.5 to VDD + 0.3	V
Input voltage (2)	VIOSC	-0.5 to VD1 + 0.3	V
Permissible total output current *1	$\Sigma I_{VDD}$	5	mA
Operating temperature	Topr	-20 to 70	°C
Storage temperature	Tstg	-65 to 150	°C
Soldering temperature / Time	Tsol	260°C, 10sec (lead section)	-
Permissible dissipation *2	PD	250	mW

\*1: The permissible total output current is the sum total of the current (average current) that simultaneously flows from the output pins (or is draw in).

\*2: In case of plastic package (QFP6-44pin, QFP12-48pin).

# E0C6262

## ● Recommended Operating Conditions

### E0C6262

(Ta=-20 to 70°C)

Condition	Symbol	Remark	Min.	Typ.	Max.	Unit
Supply voltage	V <sub>DD</sub>	V <sub>SS</sub> =0V	2.2	3.0	5.0	V
Oscillation frequency	fosc1		–	32.768	–	kHz

### E0C62L62

(Ta=-20 to 70°C)

Condition	Symbol	Remark	Min.	Typ.	Max.	Unit
Supply voltage	V <sub>DD</sub>	V <sub>SS</sub> =0V, Normal mode	1.1	1.5	2.2	V
		V <sub>SS</sub> =0V, Heavy load protection mode	0.8	1.5	2.2	V
Oscillation frequency	fosc1		–	32.768	–	kHz

### E0C62A62

(Ta=-20 to 70°C)

Condition	Symbol	Remark	Min.	Typ.	Max.	Unit
Supply voltage	V <sub>DD</sub>	V <sub>SS</sub> =0V	2.2	3.0	5.0	V
Oscillation frequency (1)	fosc1		–	32.768	–	kHz
Oscillation frequency (2)	fosc3	duty 50±5%	–	1,000	–	kHz

## ● DC Characteristics

### E0C6262/62A62

(Unless otherwise specified:

V<sub>DD</sub>=3.0V, V<sub>SS</sub>=0V, fosc1=32.768kHz, fosc3=1MHz(E0C62A62), Ta=-20 to 70°C, C1–C3=0.1μF, V<sub>DE</sub>=1.5 to 5.0V, V<sub>D1</sub> is internal voltage)

(V<sub>DD</sub> (V) used in the table means voltage supplied by V<sub>DD</sub> or V<sub>DE</sub>, use of V<sub>DD</sub> or V<sub>DE</sub> for Pads as positive power supply is selected by mask option)

Characteristic	Symbol	Condition	V <sub>DD</sub> (V)	Min.	Typ.	Max.	Unit
High level input voltage (1)	V <sub>IH1</sub>	K00–03•10–13, P00–03 P10–13•20–23•30–33	1.5	0.8•V <sub>DD</sub>		V <sub>DD</sub>	V
			3.0				
			5.0				
High level input voltage (2)	V <sub>IH2</sub>	RESET, TEST	↑	0.9•V <sub>DD</sub>		V <sub>DD</sub>	V
Low level input voltage (1)	V <sub>IL1</sub>	K00–03•10–13, P00–03 P10–13•20–23•30–33	↑	0		0.2•V <sub>DD</sub>	V
			↑	0		0.1•V <sub>DD</sub>	V
			↑	0		0.1•V <sub>DD</sub>	V
High level input current	I <sub>IH</sub>	V <sub>IH</sub> =V <sub>DD</sub> K00–03•10–13, P00–03 P10–13•20–23•30–33 RESET, TEST	↑	0		0.5	μA
Low level input current (1)	I <sub>IL1</sub>	V <sub>IL1</sub> =0V No pull-up resistor K00–03•10–13, P00–03 P10–13•20–23•30–33 RESET	↑	-0.5		0	μA
			1.5	-10		-6	μA
			3.0	-20		-12	
Low level input current (2)	I <sub>IL2</sub>	V <sub>IL2</sub> =0V With pull-up resistor K00–03•10–13 RESET, TEST	5.0	-32		-18	μA
			1.5	-45		-25	
			3.0	-85		-45	μA
5.0	-130		-70				
Low level input current (3)	I <sub>IL3</sub>	V <sub>IL3</sub> =0V With pull-up resistor (small) P00–03•10–13 P20–23•30–33	1.5	-45		-25	μA
			3.0	-85		-45	
			5.0	-130		-70	
Low level input current (4)	I <sub>IL4</sub>	V <sub>IL4</sub> =0V With pull-up resistor (large) P00–03•10–13 P20–23•30–33	1.5	-15		-8	μA
			3.0	-30		-16	
			5.0	-45		-25	
High level output current (1)	I <sub>OH1</sub>	V <sub>OH1</sub> =-0.9•V <sub>DD</sub> R00–03•10•11 P00–03•10–13 P20–23•30–33	1.5			-50	μA
			3.0			-0.3	mA
			5.0			-1.0	
High level output current (2)	I <sub>OH2</sub>	V <sub>OH2</sub> =-0.9•V <sub>DD</sub> R12•13	1.5			-100	μA
			3.0			-0.6	mA
			5.0			-2.0	
Low level output current (1)	I <sub>OL1</sub>	V <sub>OL1</sub> =-0.1•V <sub>DD</sub> R00–03•10•11 P00–03•10–13 P20–23•30–33	1.5	150			μA
			3.0	1.0			mA
			5.0	3.0			
Low level output current (2)	I <sub>OL2</sub>	V <sub>OL2</sub> =-0.1•V <sub>DD</sub> R12•13	1.5	200			μA
			3.0	1.5			mA
			5.0	4.5			

## E0C62L62

(Unless otherwise specified:  $V_{DD}=1.5V$ ,  $V_{SS}=0V$ ,  $f_{OSC1}=32.768kHz$ ,  $T_a=-20$  to  $70^{\circ}C$ ,  $C_1-C_3=0.1\mu F$ ,  $V_{DE}=1.5$  to  $5.0V$ ,  $V_{D1}$  is internal voltage)  
 ( $V_{DD}$  (V) used in the table means voltage supplied by  $V_{DD}$  or  $V_{DE}$ , use of  $V_{DD}$  or  $V_{DE}$  for Pads as positive power supply is selected by mask option)

Characteristic	Symbol	Condition	$V_{DD}$ (V)	Min.	Typ.	Max.	Unit
High level input voltage (1)	$V_{IH1}$	K00-03•10-13, P00-03 P10-13•20-23•30-33	0.8	$0.8 \cdot V_{DD}$		$V_{DD}$	V
			1.5				
			3.0				
			5.0				
High level input voltage (2)	$V_{IH2}$	RESET, TEST	↑	$0.9 \cdot V_{DD}$		$V_{DD}$	V
Low level input voltage (1)	$V_{IL1}$	K00-03•10-13, P00-03 P10-13•20-23•30-33	↑	0		$0.2 \cdot V_{DD}$	V
Low level input voltage (2)	$V_{IL2}$	RESET, TEST	↑	0		$0.1 \cdot V_{DD}$	V
High level input current	$I_{IH}$	$V_{IH}=V_{DD}$ K00-03•10-13, P00-03 P10-13•20-23•30-33	↑	0		0.5	$\mu A$
Low level input current (1)	$I_{IL1}$	$V_{IL1}=0V$ No pull-up resistor K00-03•10-13, P00-03 P10-13•20-23•30-33	↑	-0.5		0	$\mu A$
Low level input current (2)	$I_{IL2}$	$V_{IL2}=0V$ With pull-up resistor K00-03•10-13 RESET, TEST	0.8	-6		-3	$\mu A$
			1.5	-10		-6	
			3.0	-20		-12	
			5.0	-32		-18	
Low level input current (3)	$I_{IL3}$	$V_{IL3}=0V$ With pull-up resistor P00-03•10-13 P20-23•30-33	0.8	-10		-5	$\mu A$
			1.5	-15		-8	
			3.0	-30		-16	
			5.0	-45		-25	
High level output current (1)	$I_{OH1}$	$V_{OH1}=-0.9 \cdot V_{DD}$ R00-03•10•11 P00-03•10-13 P20-23•30-33	0.8			-5	$\mu A$
			1.5			-150	mA
			3.0			-1.0	
			5.0			-3.0	
High level output current (2)	$I_{OH2}$	$V_{OH2}=-0.9 \cdot V_{DD}$ R12•13	0.8			-10	$\mu A$
			1.5			-300	mA
			3.0			-2.0	
			5.0			-4.0	
Low level output current (1)	$I_{OL1}$	$V_{OL1}=-0.1 \cdot V_{DD}$ R00-03•10•11 P00-03•10-13 P20-23•30-33	0.8	20			$\mu A$
			1.5	500			mA
			3.0	3.0			
			5.0	9.0			
Low level output current (2)	$I_{OL2}$	$V_{OL2}=-0.1 \cdot V_{DD}$ R12•13	0.8	30			$\mu A$
			1.5	750			mA
			3.0	4.5			
			5.0	13.5			

## ● Analog Circuit Characteristics and Current Consumption

### E0C6262

(Unless otherwise specified:  $V_{DD}=3.0V$ ,  $V_{SS}=0V$ ,  $f_{OSC1}=32.768kHz$ ,  $T_a=25^{\circ}C$ ,  $C_G=25pF$ ,  $V_{D1}$  is internal voltage,  $C_1=0.1\mu F$ )

Characteristic	Symbol	Condition	Min.	Typ.	Max.	Unit
SVD voltage	$V_{SVD}$	Level 1	2.10	2.20	2.30	V
		Level 2	2.30	2.40	2.50	V
SVD circuit response time	$t_{SVD}$				100	$\mu S$
Current consumption	IOP	During HALT *1		3.0	5.0	$\mu A$
		During operation *1		7.0	10.0	$\mu A$

\*1: The SVD circuit is turned off.

### E0C62L62

(Unless otherwise specified:  $V_{DD}=1.5V$ ,  $V_{SS}=0V$ ,  $f_{OSC1}=32.768kHz$ ,  $T_a=25^{\circ}C$ ,  $C_G=25pF$ ,  $V_{D1}$  and  $V_{D2}$  are internal voltage,  $C_1-C_3=0.1\mu F$ )

Characteristic	Symbol	Condition	Min.	Typ.	Max.	Unit
SVD voltage	$V_{SVD}$	Level 1	1.05	1.10	1.15	V
		Level 2	1.15	1.20	1.25	V
SVD circuit response time	$t_{SVD}$				100	$\mu S$
Current consumption	IOP	During HALT *1		2.0	4.0	$\mu A$
		During operation *1		5.0	7.5	$\mu A$

\*1: The SVD circuit is turned off.

# E0C6262

## E0C62A62

(Unless otherwise specified: V<sub>DD</sub>=3.0V, V<sub>SS</sub>=0V, f<sub>osc1</sub>=32.768kHz, T<sub>a</sub>=25°C, C<sub>G</sub>=25pF, V<sub>D1</sub> is internal voltage, C<sub>1</sub>=0.1μF)

Characteristic	Symbol	Condition	Min.	Typ.	Max.	Unit
SVD voltage	V <sub>SVD</sub>	Level 1	2.10	2.20	2.30	V
		Level 2	2.30	2.40	2.50	V
SVD circuit response time	t <sub>svd</sub>				100	μS
Current consumption	I <sub>OP</sub>	During HALT *1		3.0	5.0	μA
		During operation at 32kHz *1		7.0	10.0	μA
		During operation at 1MHz *1		300	450	μA

\*1: The SVD circuit is turned off.

## ● Oscillation Characteristics

The oscillation characteristics change depending on the conditions (components used, board pattern, etc.). Use the following characteristics as reference values.

### E0C6262/62A62 (Crystal oscillation circuit)

(Unless otherwise specified: V<sub>DD</sub>=3.0V, V<sub>SS</sub>=0V, Crystal: C-002R (C<sub>I</sub>=35kΩ), C<sub>G</sub>=25pF, C<sub>D</sub>=built-in, T<sub>a</sub>=25°C)

Characteristic	Symbol	Condition	Min.	Typ.	Max.	Unit
Oscillation start voltage	V <sub>sta</sub>	t <sub>sta</sub> ≤3sec (V <sub>DD</sub> )	2.2			V
Oscillation stop voltage	V <sub>stp</sub>	t <sub>stp</sub> ≤10sec (V <sub>DD</sub> )	2.2			V
Built-in capacitance (drain)	C <sub>D</sub>	Including the parasitic capacity inside the IC		20		pF
Frequency/voltage deviation	∂f/∂V	V <sub>DD</sub> =2.2 to 5.0V			5	ppm
Frequency/IC deviation	∂f/∂IC		-10		10	ppm
Frequency adjustment range	∂f/∂C <sub>G</sub>	C <sub>G</sub> =5 to 25pF	35	45		ppm
Harmonic oscillation start voltage	V <sub>hho</sub>	(V <sub>DD</sub> )	5.0			V
Permitted leak resistance	R <sub>leak</sub>	Between OSC1 and V <sub>DD</sub> , V <sub>SS</sub>	200			MΩ

### E0C62L62 (Crystal oscillation circuit)

(Unless otherwise specified: V<sub>DD</sub>=1.5V, V<sub>SS</sub>=0V, Crystal: C-002R (C<sub>I</sub>=35kΩ), C<sub>G</sub>=25pF, C<sub>D</sub>=built-in, T<sub>a</sub>=25°C)

Characteristic	Symbol	Condition	Min.	Typ.	Max.	Unit
Oscillation start voltage	V <sub>sta</sub>	t <sub>sta</sub> ≤3sec (V <sub>DD</sub> )	0.9			V
Oscillation stop voltage	V <sub>stp</sub>	t <sub>stp</sub> ≤10sec (V <sub>DD</sub> )	0.8			V
Built-in capacitance (drain)	C <sub>D</sub>	Including the parasitic capacity inside the IC		20		pF
Frequency/voltage deviation	∂f/∂V	V <sub>DD</sub> =0.9 to 2.2V			5	ppm
Frequency/IC deviation	∂f/∂IC		-10		10	ppm
Frequency adjustment range	∂f/∂C <sub>G</sub>	C <sub>G</sub> =5 to 25pF	35	45		ppm
Harmonic oscillation start voltage	V <sub>hho</sub>	(V <sub>DD</sub> )	2.2			V
Permitted leak resistance	R <sub>leak</sub>	Between OSC1 and V <sub>DD</sub> , V <sub>SS</sub>	200			MΩ

### E0C62A62 (CR oscillation circuit)

(Unless otherwise specified: V<sub>DD</sub>=3.0V, V<sub>SS</sub>=0V, R<sub>CR</sub>=35kΩ, T<sub>a</sub>=25°C)

Characteristic	Symbol	Condition	Min.	Typ.	Max.	Unit
Oscillation frequency dispersion	f <sub>osc3</sub>		-30	1000kHz	30	%
Oscillation start voltage	V <sub>sta</sub>	(V <sub>DD</sub> )	2.2			V
Oscillation start time	t <sub>sta</sub>	V <sub>DD</sub> =2.2 to 5.0V			3	mS
Oscillation stop voltage	V <sub>stp</sub>	(V <sub>DD</sub> )	2.2			V

### E0C62A62 (Ceramic oscillation circuit)

(Unless otherwise specified: V<sub>DD</sub>=3.0V, V<sub>SS</sub>=0V, Ceramic oscillation: 1MHz, C<sub>GC</sub>=C<sub>DC</sub>=100pF, T<sub>a</sub>=25°C)

Characteristic	Symbol	Condition	Min.	Typ.	Max.	Unit
Oscillation start voltage	V <sub>sta</sub>	(V <sub>DD</sub> )	2.2			V
Oscillation start time	t <sub>sta</sub>	V <sub>DD</sub> =2.2 to 5.0V			5	mS
Oscillation stop voltage	V <sub>stp</sub>	(V <sub>DD</sub> )	2.2			V

■ BASIC EXTERNAL CONNECTION DIAGRAM

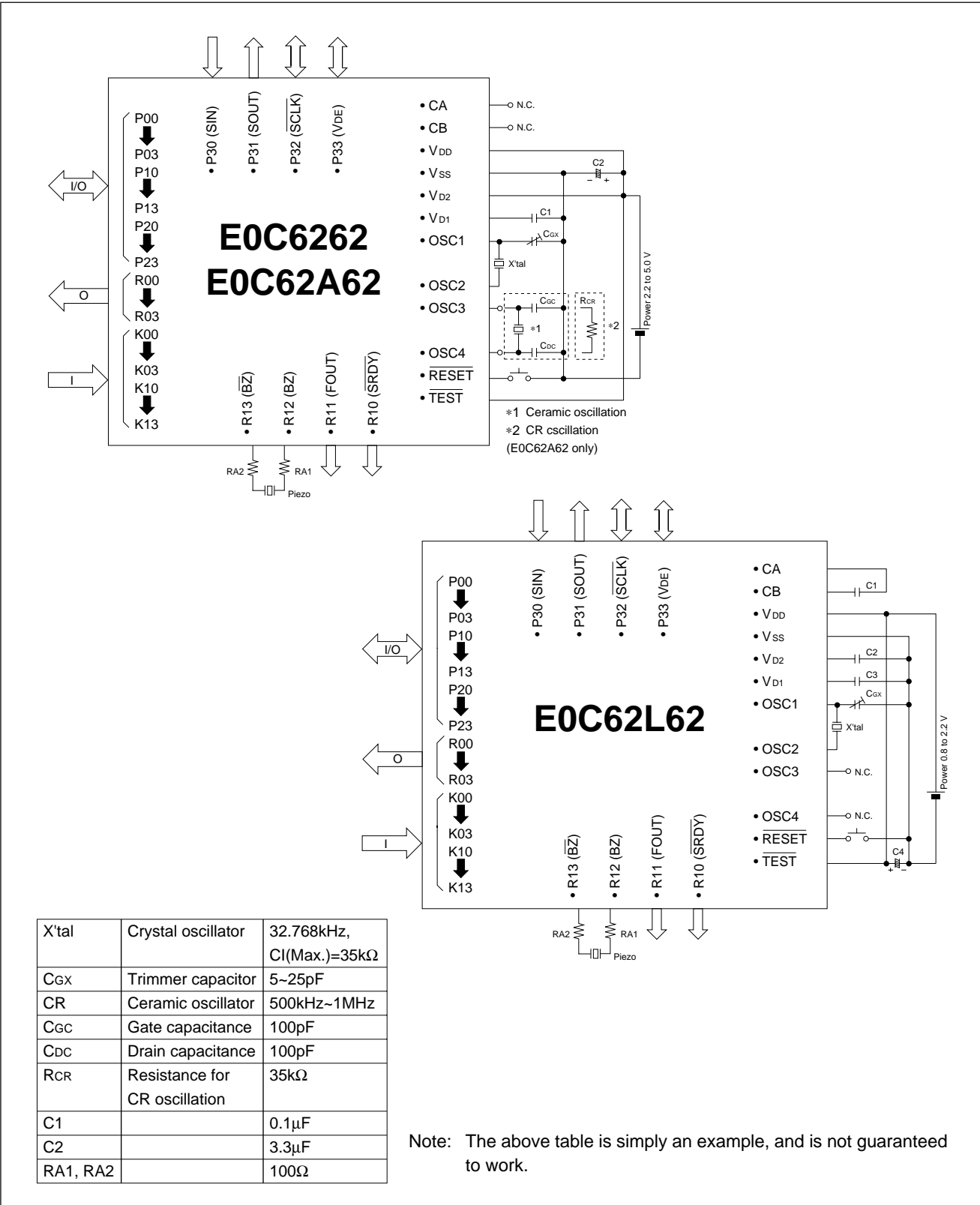

## ■ PACKAGE DIMENSIONS

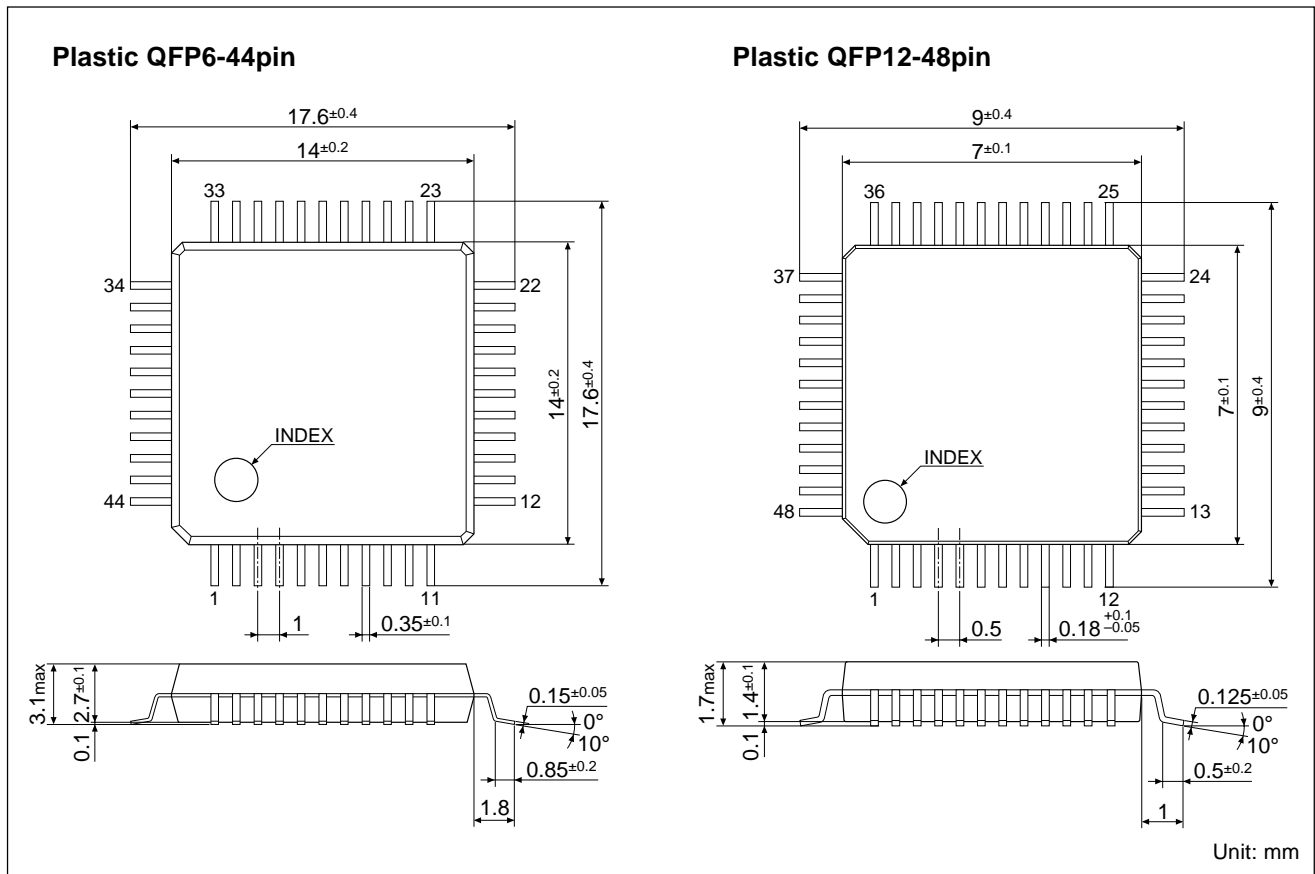

### NOTICE:

No part of this material may be reproduced or duplicated in any form or by any means without the written permission of Seiko Epson. Seiko Epson reserves the right to make changes to this material without notice. Seiko Epson does not assume any liability of any kind arising out of any inaccuracies contained in this material or due to its application or use in any product or circuit and, further, there is no representation that this material is applicable to products requiring high level reliability, such as, medical products. Moreover, no license to any intellectual property rights is granted by implication or otherwise, and there is no representation or warranty that anything made in accordance with this material will be free from any patent or copyright infringement of a third party. This material or portions thereof may contain technology or the subject relating to strategic products under the control of the Foreign Exchange and Foreign Trade Control Law of Japan and may require an export license from the Ministry of International Trade and Industry or other approval from another government agency.

© Seiko Epson Corporation 1999 All right reserved.

### SEIKO EPSON CORPORATION

ELECTRONIC DEVICES MARKETING DIVISION

IC Marketing & Engineering Group

#### ED International Marketing Department I (Europe & U.S.A.)

421-8, Hino, Hino-shi, Tokyo 191-8501, JAPAN

Phone : 042-587-5812 FAX : 042-587-5564

#### ED International Marketing Department II (Asia)

421-8, Hino, Hino-shi, Tokyo 191-8501, JAPAN

Phone : 042-587-5814 FAX : 042-587-5110

